

SIEMENS

SIMELEC

Avda. San Ignacio de Loyola,185
24191 - San Andrés del Rabanedo
León - Spain



7641

ISO 9001



Tel.: +34 987 248 305

Email: simelec@simelec.es
www.simelec.es



Electrohydraulic Actuators

SKP1...

Gas Pressure Governors

SKP2...

Gas Valves

VGG... VGF... VGH...

On / off safety shut-off valves, 2-stage or with integrated constant or balanced gas pressure governor; for natural gas, town gas or liquefied petroleum gas in the low pressure range.

Electrohydraulic actuators featuring delayed opening and rapid closing.

The SKP1... / SKP2... / VG... and this Data Sheet are intended for use by OEMs which integrate the actuators and gas valves in their products!

Use

The VG... gas valves with their electrohydraulic SKP... actuators are designed for gas families I, II, III and air. They are used primarily in gas-fired combustion plant. The valves open slowly and close rapidly. All types of VG... gas valves can be combined with the available types of actuators. The actuator is fitted to the valve body by means of the 4 screws contained in the terminal compartment. The square flange can be turned in steps of 90°, thus providing 4 different mounting positions. The actuator can be fitted or replaced while the valve is under pressure. Sealing materials are not required. Actuator type SKP2... is equipped with an integrated precision gas pressure governor. This type of actuator with gas pressure governor not only reduces the length of the gas train, but usually also permits selection of a smaller valve size. For detailed information about valve sizing, refer to «Flow chart». The actuator is also available with limit and auxiliary changeover switches, e.g. for indicating the fully closed position or for stroke limitation in connection with 2-stage gas release, etc.

The **SKP20.130...** operates as a balanced gas pressure governor and controls the gas pressure according to the pressure of the combustion air so that the gas / air ratio remains constant over the entire load range (shifting the setpoint by the static pressure of the combustion air).

Therefore – in contrast to conventional gas / air ratio control – air volume changes due to mains pressure variations, soiled fan wheel, etc., have no impact on the quality of the combustion process.

Warning notes



To avoid injury to persons, damage to property or the environment, the following warning notes should be observed!

Is not permitted to open, interfere with or modify the actuators and valves.

- Before performing any wiring changes in the connection area of the SKP1... / SKP2..., completely isolate the actuator from the mains supply
- Ensure protection against electric shock hazard by providing adequate protection for the connection terminals
- Only with SKP13.111B27 and SKP23.111B27:
Prior to connecting auxiliary switch IV, pull out the plug
- Check wiring and all safety functions
- Fall or shock can adversely affect the safety functions. Such actuators and valves may not be put into operation even if they do not exhibit any damage

Mounting notes

The relevant national safety regulations must be complied with.

Installation notes

- Installation work must be carried by qualified staff
- When using the SKP2... actuator with attached gas pressure governor, the gas pressure monitor for lack of gas must always be mounted upstream of the valve
- When using the auxiliary switch, the earth conductor of the connecting cable must be connected to the earth terminal in the housing

Commissioning notes

Commissioning and maintenance work must be carried out by qualified staff.

Service notes

- VGH... valves may only be overhauled by Landis & Staefa Repair Centers
- VGH... valves are supplied without strainer. They must be installed either with a gas filter upstream of the valve or an AGK... strainer (refer to «Accessories») on the valve's gas inlet side

Disposal



The unit contains electrical components, electronic components and hydraulic oil, it is not allowed throwing into household garbage. Pay attention to the local and actualize law.

Mechanical design

Actuator SKP1...

The actuator's hydraulic drive system consists of a cylinder filled with oil and an electric oscillating pump with piston and relief valve. The relief valve is located in the bypass between the suction and pressure side of the pump. With the actuators of the B-series, it is a valve hydraulically actuated by the pump pressure; with the 2-stage actuators of the A-series, it is a normally open solenoid valve. The cylinder carries a seal which hydraulically separates the inlet from the outlet side of the pump, also serving as a guidance for the piston. The piston is also guided by a rod which is rigidly connected to it. This rod transfers the piston's travel directly to the valve stem. The rod is provided with a disk the position of which is visible through a window in the console (indication of stroke).

Using a lever system, the disk also actuates

- the auxiliary switch for indicating the fully closed position, or
- other positions, as well as the limit changeover switches for positioning the low- and high-fire stroke with the two-stage actuators.

The switching points of these switches are adjustable over the entire stroke. The adjusting screws are located in the terminal compartment.

Basic design

(Sectional view of SKP1... and VG... / VL...)

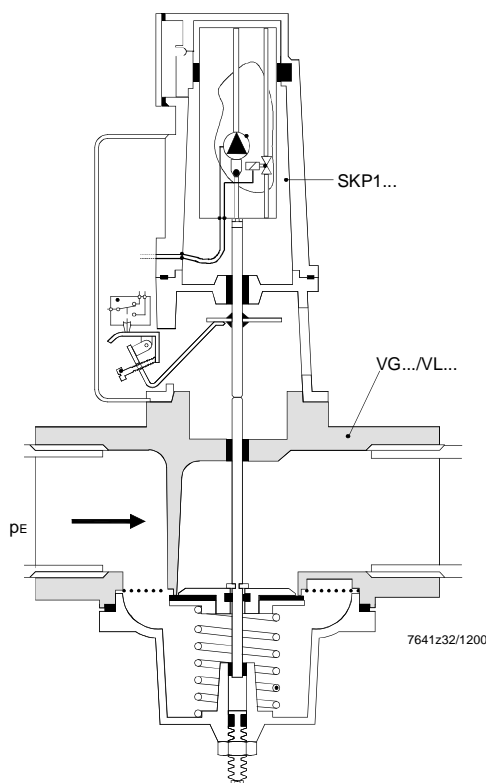

Actuator SKP2... with
gas pressure governor

The gas pressure governor consists of

- working diaphragm
- safety diaphragm
- setpoint spring
- lever system for actuating a ball valve located in the bypass between the suction and pressure side of the hydraulic system (refer to «Function»).

The setpoint adjustment can be sealed.

The impulse pipe connection is Rp $\frac{1}{4}$.

The housings of actuator and governor are made of die-cast aluminium and the seals are made of elastomer.

Basic design

(Sectional view of SKP2... and VG... / VL...)

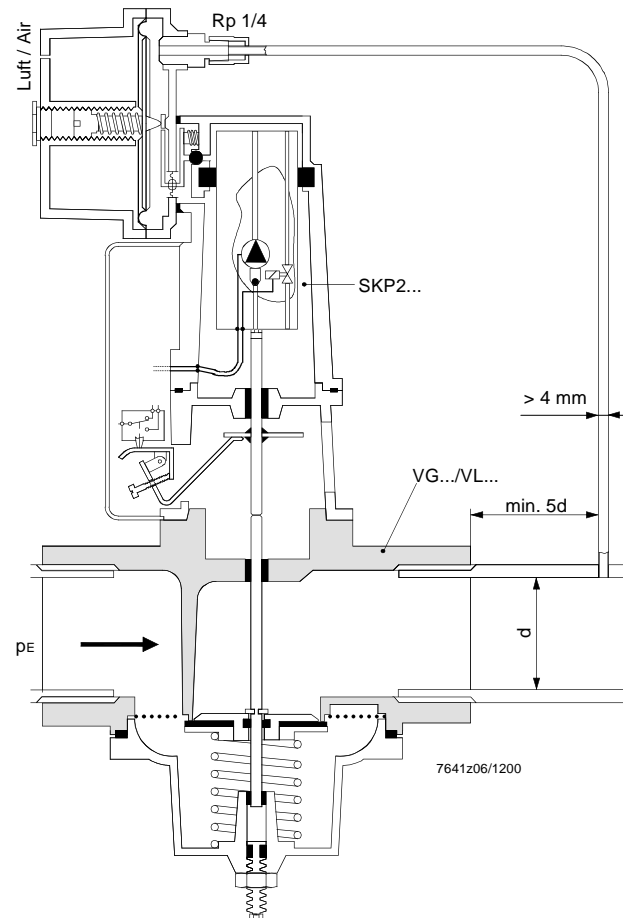

Valves VGG... and VGF...

These valves are normally closed one-way disk type valves. Their stem is guided on both sides of the disk, thus ensuring precise alignment of the stroke as well as tight shut-off. The closing force of the return spring is supported by the prevailing gas pressure. The valves are available with profiled or flat disks and with or without stroke limitation (refer to «Type summary»). An interchangeable strainer made of stainless steel protects seat and disk as well as downstream controls from dirt.

Basic design of valves VGG... and VGF...

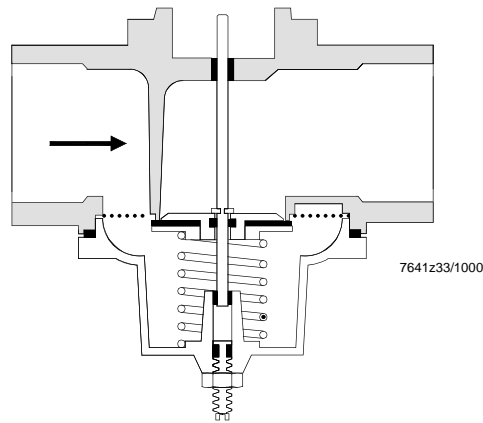

Valves VGH...

These valves are normally closed one-way high-flow type valves. The swing-type flap has no profile. The great closing force of the return spring is supported by the prevailing gas pressure. An AGA... strainer is available as an accessory item (refer to «Accessories»). The valves are supplied without strainer.

Basic design of valves VGH...

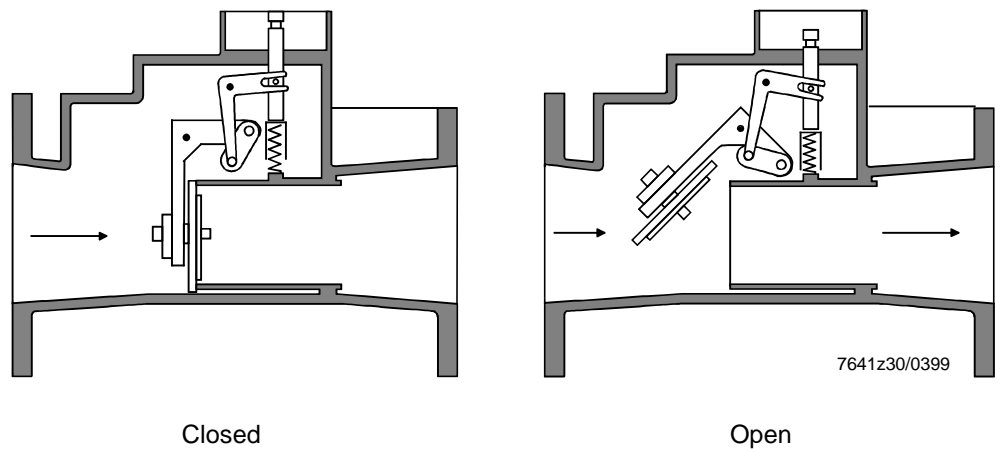

Type summary

SKP1... / SKP2... for use with VG... valves

The complete gas shut-off assembly or pressure control section consists of actuator and valve.

Actuators		
Mains voltage	AC 100...110 V	AC 220...240 V
Single-stage opening and closing; without limit and auxiliary changeover switches		
Without pressure governor	SKP10.110B17	SKP10.110B27
	Not in the range	SKP13.110B27
With pressure governor up to 22 mbar	SKP20.110B17	SKP20.110B27
	Not in the range	SKP23.110B27
Balanced pressure governor	Not in the range	SKP20.130C27
Single-stage opening and closing; one auxiliary changeover switch		
Without pressure governor	SKP10.111B17	SKP10.111B27
	Not in the range	SKP13.111B27
With pressure governor up to 22 mbar	SKP20.111B17	SKP20.111B27
	Not in the range	SKP23.111B27
Balanced pressure governor	Not in the range	Not in the range
2-stage opening and closing; with 2 limit switches and one auxiliary changeover switch		
Without pressure governor	SKP10.123B17	SKP10.123B27
With pressure governor up to 22 mbar	Not in the range	Not in the range
Balanced pressure governor	Not in the range	Not in the range

Accessories for gas pressure governor

Setpoint springs



- 15...120 mbar (yellow)

AGA22



- 100...250 mbar (red)

AGA23



Damping throttle (refer to «Charts»)

AGA25



Connecting cable

(Not included in delivery, must be ordered as a separate item)

AGA62.000A27

Valves

The SKP1... / SKP2... are suited for use with the following types of valves:		
Type reference	Medium	Data Sheet
VGG... / VGF... / VGH...	Natural gas families I, II, III	7641
VGD20... VGD40...	Natural gas families I, II, III	7631
VRF... / VRH...	Biogas	7633
VLG... / VLF...	Cold and hot air	7637

Nominal size	Valve body material	Perm. operating pressure in mbar		Flow rate of air at $\Delta p = 1$ mbar / m ³ / h	Number of connections		Type reference				Replacement set part no.
		Europe and Australia (to EN)	Other countries		Test point RP $\frac{1}{4}$ ⁵⁾	Pilot gas G $\frac{3}{4}$ ⁶⁾	With profile		Without profile		
							Without adjustable stroke limitation	With adjustable stroke limitation ¹⁾	Without adjustable stroke limitation	With adjustable stroke limitation ¹⁾	
Internally threaded to ISO 7/1											
½"	Die-cast Al	1200	1200	4.8	4	---	VGG10.154P	VGG10.1541P ²⁾	... ⁴⁾	... ⁴⁾	4 679 1560 0
¾"	Die-cast Al	1200	1200	8.9	4	---	VGG10.204P	VGG10.2041P ²⁾	VGG10.204	VGG10.2041 ²⁾	4 679 1492 0
1"	Die-cast Al	1200	1200	13.3	4	---	VGG10.254P	VGG10.2541P ²⁾	VGG10.254	VGG10.2541 ²⁾	4 679 1493 0
1 ½"	Die-cast Al	600	600	32.3	4	---	VGG10.404P	VGG10.4041P	VGG10.404	VGG10.4041	4 679 1494 0
2"	Die-cast Al	600	600	47.4	4	---	VGG10.504P	VGG10.5041P	VGG10.504	VGG10.5041	4 679 1495 0
3"	Grauguss	600	600	85.4	2	2	VGG10.804P	VGG10.8041P	VGG10.804	VGG10.8041	4 679 1559 0 ³⁾
Flanged, PN16, to ISO 7005											
DN40	Cast iron	600	600	32.3	4	---	VGF10.404P	VGF10.4041P	VGF10.404	VGF10.4041	4 679 1494 0
DN50	Cast iron	600	600	47.4	4	---	VGF10.504P	VGF10.5041P	VGF10.504	VGF10.5041	4 679 1495 0
DN65	Cast iron	600	600	74	2	2	VGF10.654P	VGF10.6541P	VGF10.654	VGF10.6541	4 679 1558 0 ³⁾
DN80	Cast iron	600	600	85.4	2	2	VGF10.804P	VGF10.8041P	VGF10.804	VGF10.8041	4 679 1559 0 ³⁾
Disk type valves, high-flow, with swing-type flap. Great closing force. Without strainer, to DIN, can only be used in plants with gas filter. These valves may only be overhauled by Landis & Staefa Repair Centers.											
DN80	Cast iron	300	600	128.4	4	1	---	---	VGH10.18050	---	---
DN100	Cast iron	300	400	199.5	4	1	---	---	VGH10.19050	---	---
DN125	Cast iron	300	300	277.6	4	1	---	---	VGH10.19150	---	---

- 1) **Not** for use with integrated gas pressure governor!
2) Flow rate 20 % lower

- 3) Refer to notes «Replacement sets»!
4) Only available with profile
5) Equal share on inlet and outlet side

- 6) On inlet side, VGG... and VGF...: one connection on each side

for VGH10.18050	DN80	AGA80
for VGH10.19050	DN100	AGA90
for VGH10.19150	DN125	AGA91

Replacement sets consisting of stem, disk, strainer, screws, washers and gaskets.

For part nos., refer to «Type summary / Valves».
No replacement sets are available for VGH... valves.

All service replacements sets can also be used with the predecessor type, with the exception of:

Type reference	DN / Dim.	Part no.
VGf10.1655...	65	4 679 9501 0
VGG10.1805	3"	4 679 9502 0
VGf10.1805...	80	4 679 9502 0



When used with gas, the valves constitute part of the safety equipment.
Any opening, exchanging parts or modifying the original equipment is undertaken at the user's own responsibility and risk.

Ordering

When ordering, please give name and type reference.

Example:

- Actuator
 - AC 220...240 V / 50 Hz
- SKP10.111B27** - Without limit and auxiliary changeover switches

Technical Data

SKP...

General valve data

Mains voltage (refer to «Type summary»)	AC 220 V -15 %...AC 240 V +10 % AC 100 V -15 %...AC 110 V +10 %
Mains frequency	50...60 Hz ±6 %
Power consumption (depending on mains voltage)	max. 20 VA
Switching capacity of auxiliary switch IV	6 (2) A, AC 250 V (if built in)
Setting range of auxiliary switch	4...96 % stroke (if built in)
On time	100 %
Opening time for full stroke approx. 2 mm / s	depending on nominal size 6...12 s (extended opening time below 0 °C)
Closing time	< 1 s
Mounting position	

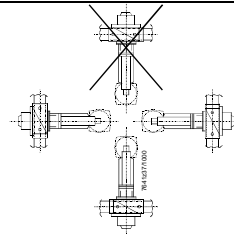

Degree of protection	IP 54
Weight	
- Without governor	approx. 1250 g
- with governor	approx. 1650 g

Norms and standards

Environmental conditions

Transport	IEC 721-3-2
Climatic conditions	class 2K2
Mechanical conditions	class 2M2
Temperature range	-15...+60 °C (extended opening time below 0 °C)
Humidity	< 95 % r.h.
Operation	IEC 721-3-3
Climatic conditions	class 3K5
Mechanical conditions	class 3M2
Temperature range	-15...+60 °C (extended opening time below 0 °C)
Humidity	< 95 % r.h.



Condensations, formation of ice and ingress of water are not permitted!

CE conformity

According to the directives of the European Union	
Electromagnetic compatibility EMC	89 / 336 EWG incl. 92 / 31 EWG
Directive for gas-fired appliances	90 / 396 EWG

Gas pressure governor

General data

Control class	A to DIN EN 88
Control mode	P (proportional)
Setting range	0...250 mbar
Vent pipe	not required with inlet pressures up to 100 mbar
Recommended min. distance between impulse pipe connection and gas valve	5 x nominal size
Dia. of impulse pipes	min. 4 mm
Impulse pipe connections	internally threaded Rp ¼
Max. inlet pressure	like valve
Perm. test pressure «PG»	1 bar
Perm. vacuum «PG»	200 mbar
Balanced pressure governor (only SKP20.130B27)	EN 12067-1
Compensating variable	pressure of combustion air
Pressure of combustion air	max. 50 mbar

Valves

General valve data

Valve class	A to EN 161
Valve group	2
Perm. medium temperature	max. + 60 °C
Operating pressure, etc.	refer to «Type summary»
Types of gas to DVGW	gas families I, II, III and air
Weight	refer to «Dimensions table»

Functions

Single-stage actuators	<p>When an opening command is given, the pump is switched on and the relief valve closed.</p> <p>From the nearly filled reservoir below the piston, the oil is now pumped into the chamber above the piston, causing the piston to move downwards and thus opening the valve – against the force of the return spring.</p> <p>The pump remains activated until a closing command is given.</p> <p>When closing, or in the event of a power failure, the pump stops and the relief valve opens the bypass, allowing the return spring to push the piston upward again.</p> <p>The relief valve is sized such that the gas valve fully closes within about 0.6 seconds.</p>
2-stage actuators	<p>With these actuators, opening starts the same way as with the single-stage actuators.</p> <p>However, when the low-fire position is reached, the disk actuates switch «V1» via a lever system, which is adjusted for the low-fire stroke.</p> <p>The pump is now switched off so that the valve disk maintains its present position.</p> <p>The pump will not be activated again until the burner control feeds power to terminal 3 of the actuator – be it directly or via the load controller.</p> <p>High-fire stroke is reached when switch «V2» switches over, thus cutting the power supply to the pump.</p> <p>If the load controller cuts the power supply to terminal 3, the relief valve is opened until the low-fire position is reached.</p> <p>If terminals 1 and 3 are without power, the actuator returns to its fully closed position in less than 1 second.</p>
Actuators with gas pressure governor	<p>When using a gas pressure governor, the outlet pressure acting on the diaphragm represents the actual value.</p> <p>The diaphragm is supported by a spring the force of which is adjustable, representing the setpoint.</p> <p>The movements of the diaphragm are transferred to a lever system which acts on a ball valve located in the bypass between the suction and pressure side of the pump.</p> <p>If the actual value lies below the setpoint, the bypass is closed so that the actuator can open the gas valve.</p> <p>If the actual value exceeds the setpoint, the bypass is opened to some degree so that a certain amount of oil can return from the pressure side to the reservoir.</p> <p>The piston travels upward and the gas valve closes a little bit more.</p> <p>This counter-movement ends as soon as the actual value equals the setpoint.</p> <p>In this position, the opening of the bypass is such that the return flow through the bypass corresponds to the current oil output of the pump.</p> <p>Control accuracy is very good since small movements of the diaphragm are sufficient to trigger the control functions described above.</p> <p>The control characteristics are that of a P-controller with a very small proportional band.</p>

SKPx3... with
connecting cable



Assignment of connection terminal

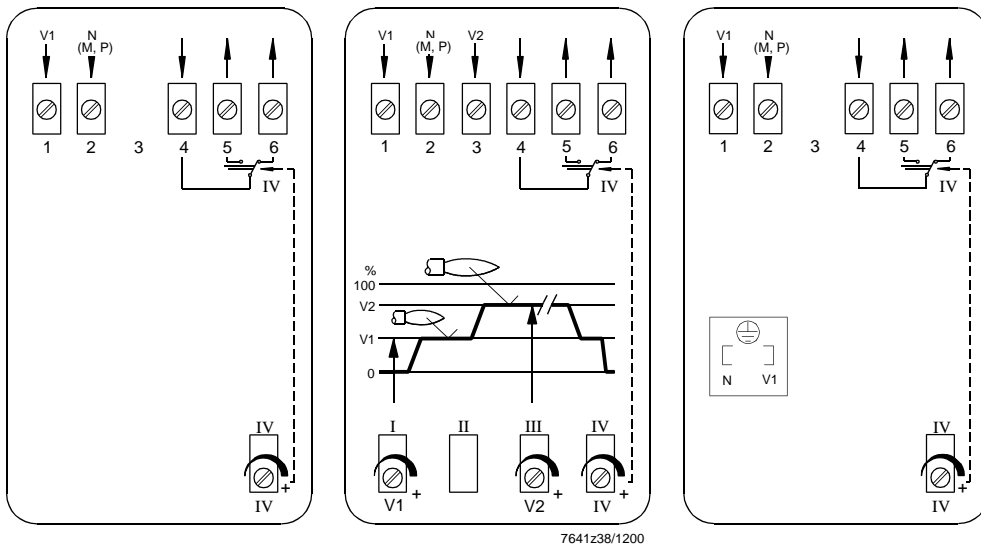

Single-stage

2-stage ON or OFF

Only with SKP13...
or SKP23...
single-stage

Legend

- V Control input
- V1 Control input stage 1
- V2 Control input stage 2
- IV Screw for setting the switching point of auxiliary changeover switch IV
-  Fuses, etc., must comply with local regulations

Connection diagram, single-stage with auxiliary changeover switch

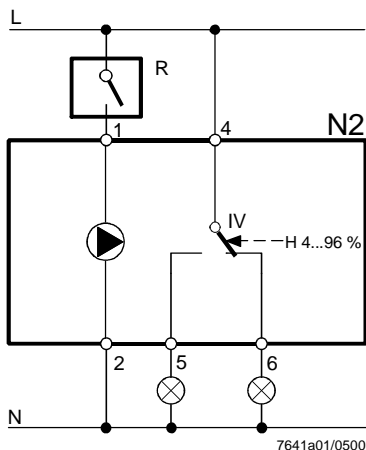

Legend

- IV Potential-free auxiliary switch (adjustable), refer to «Technical Data» (only with actuators using auxiliary switches, refer to «Type summary»)
- H Stroke of stem
- R Temperature or pressure controller, switch, ...
- N2 Actuator SKP...

Minimum flow rate required when using the SKP2... actuator

The charts below show the minimum flow rates «Q» required, depending on the inlet pressure «Pi» and outlet pressure «Po» adjusted on the gas pressure governor.

The flow rate may never fall below these minimum levels because too small flow rates at high inlet pressures cause pressure control to hunt.

By screwing the **AGA25** damping throttle into the governor's vent opening, oscillations can be suppressed to a certain degree (start-up characteristic with low-fire loads).

The limit values are thus lower than those given in the charts below.

All curves of the VGG... and VGF... are only applicable to the valve types with profile (VG...P)

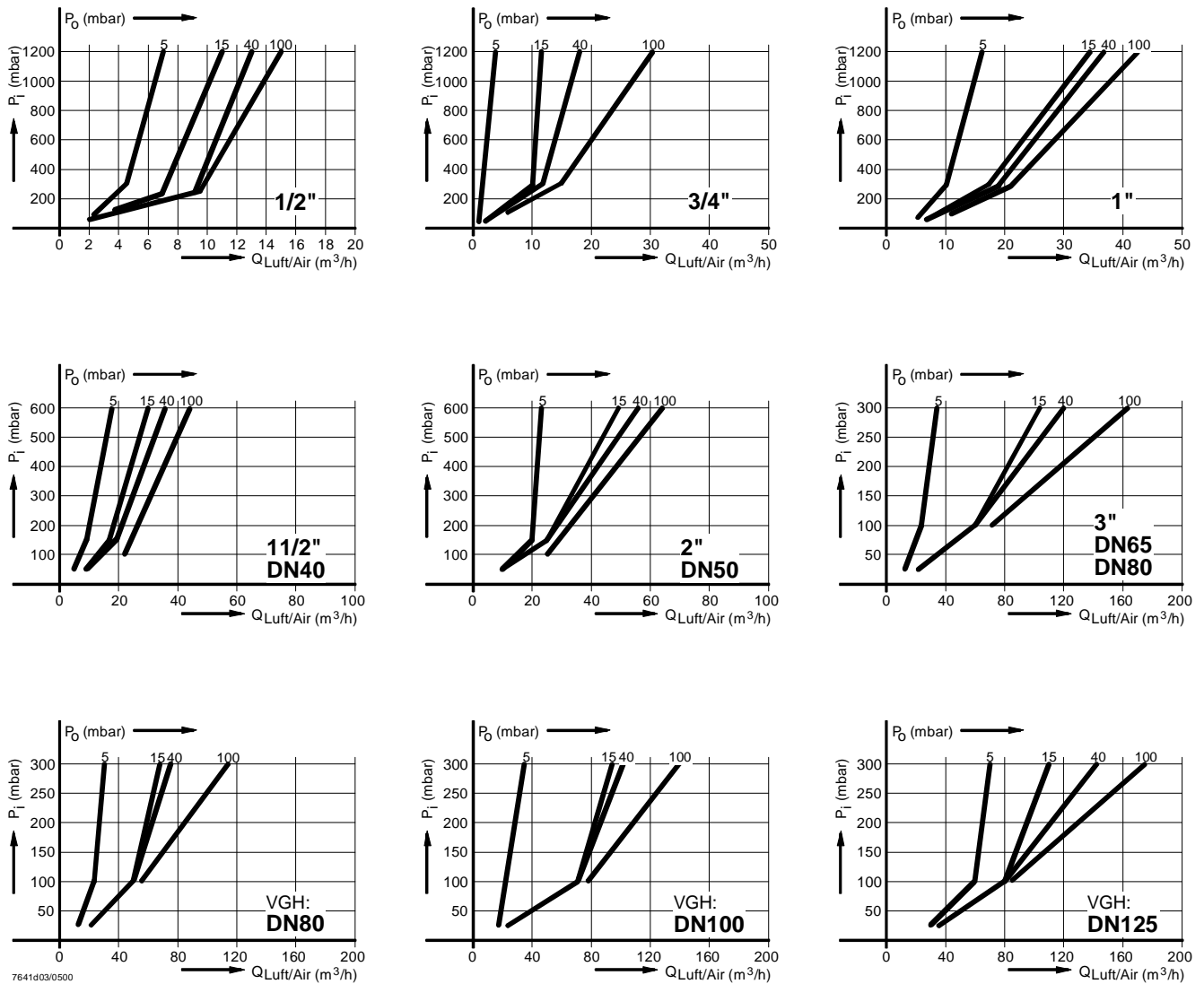

Example for 2" valves

Pi = 300 mbar
Po = 100 mbar

Qmin = 40 m³ / h air
 = 40 x 1.24 m³ / h natural gas
 = 49.6 m³ / h natural gas

7641d04e/0201

Flow chart 1)

For control performance reasons, when using the SKP20... actuators with integrated governor, the nominal valve size should not be too large. This applies in particular to burners burning small amounts of gas in the low-fire position and to burners changing from high-fire to low-fire in less than 5 s.

Conversion factors

- 1 Natural gas 1.24
- 2 Liquefied petroleum gas 0.77
- 3 Town gas 1
- 4 Air f = 1

Calculation of factor "f" for other types of gases

$$f = \sqrt{\frac{1}{d_v(\text{gas})}}$$

d_v = density ratio to air

- 1) Corresponding to a fully open valve or governor
- 2) Without strainers
- 3) Flow rate of valves with throttle 20 % lower

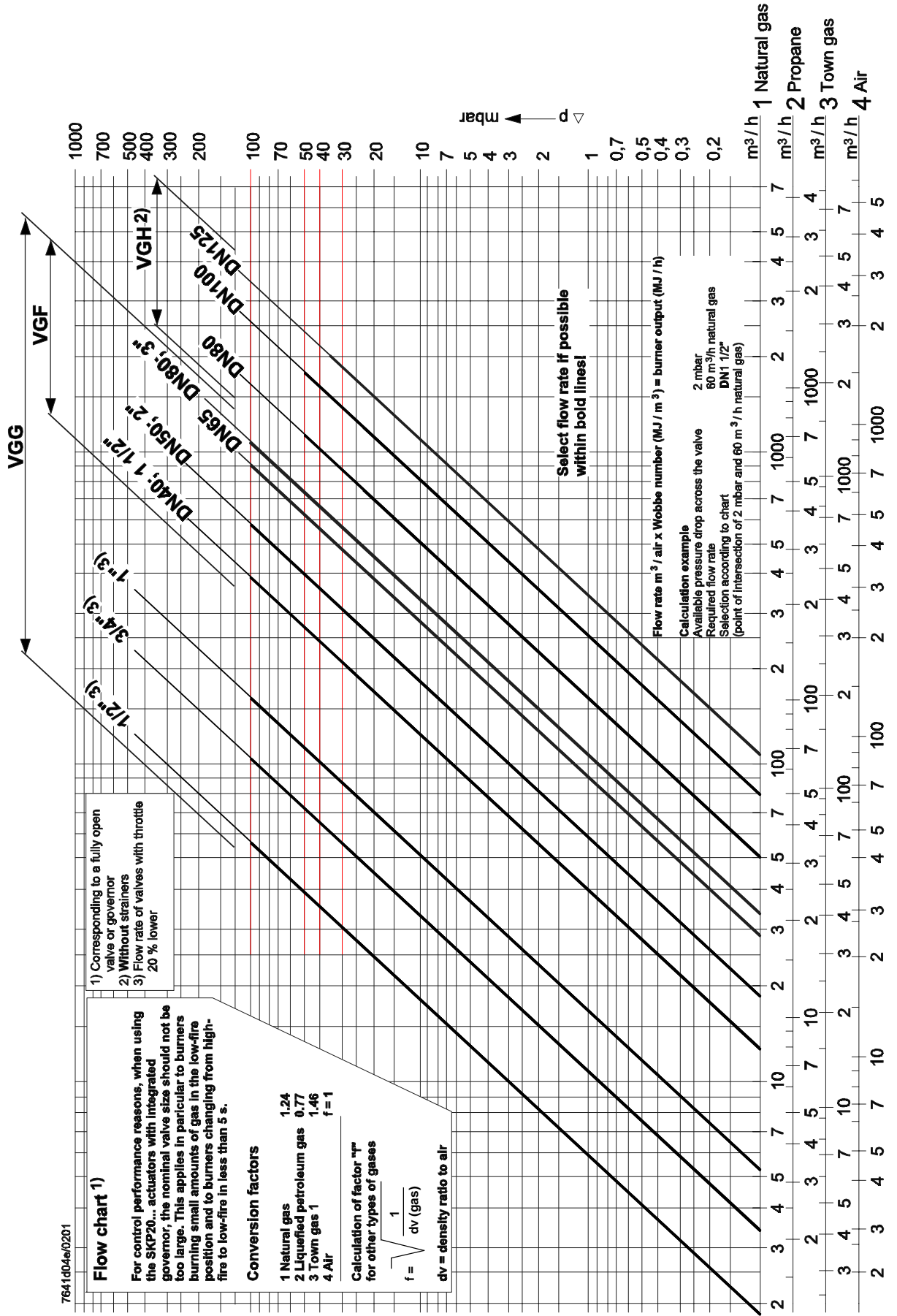

Dimensions

Dimensions in mm

SKP10...

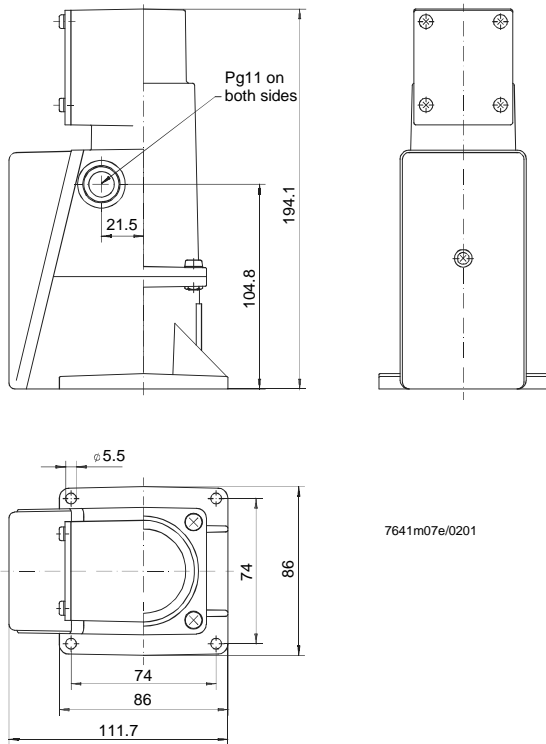

SKP20...

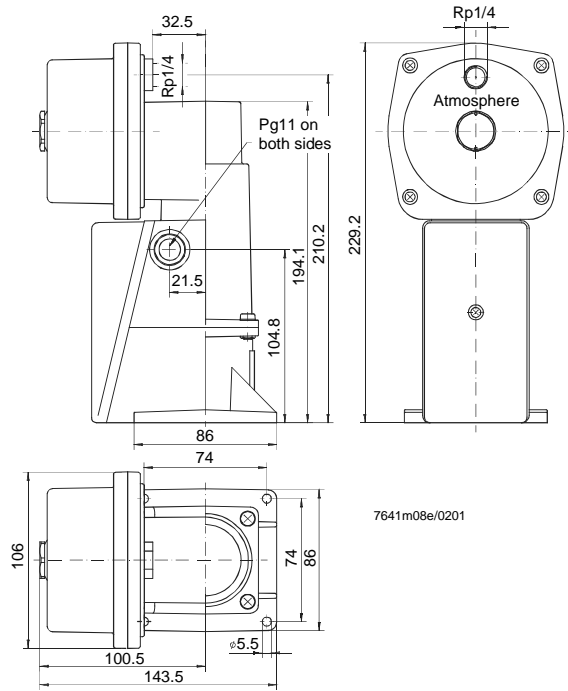

Cover with connector for SKP13... / SKP23...

Cover with connector to DIN 43650 design A (ISO 4400)

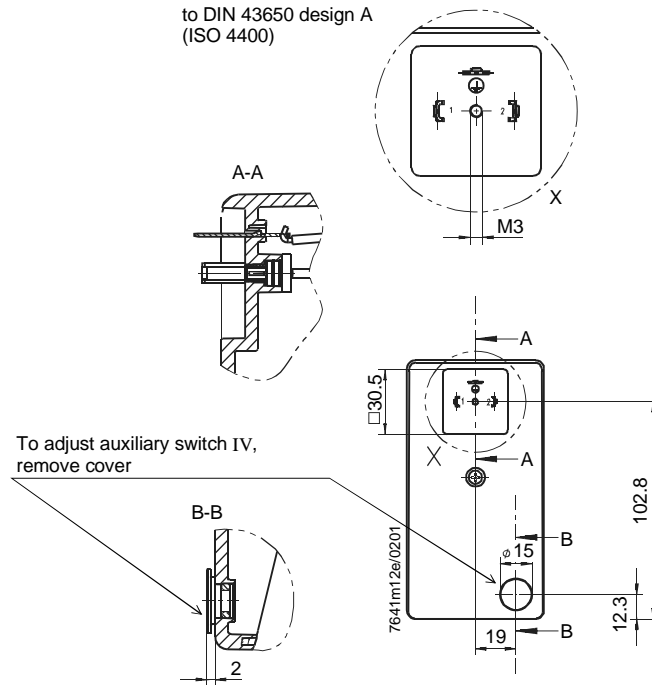

Connecting cable for SKP13... or SKP23...

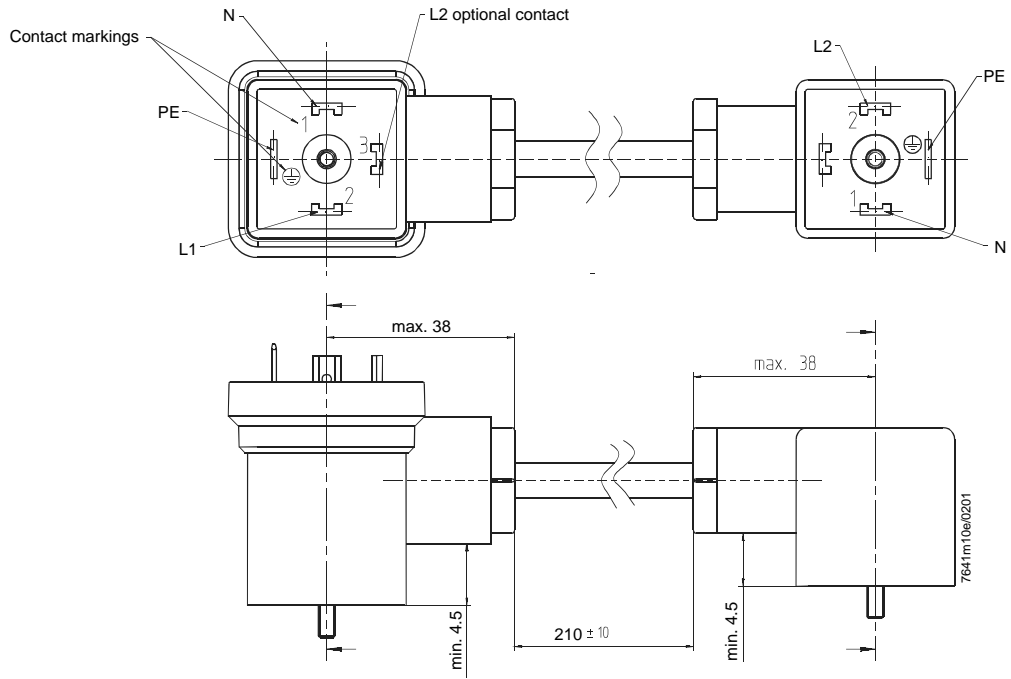

Dimensions and weights of valves without actuator

Type		A	B	C	D	E □	F	G	G´	H	J	K	LØ	MØ	NØ	P	Q	R 1)	S	T	SW*	kg
VGG...	½"	---	---	96	79	80	109	---	---	---	32	---	---	---	---	---	---	---	28	31	46	0.8
	¾"	---	---	96	79	80	109	---	---	---	32	---	---	---	---	---	---	---	28	31	46	0.8
	1"	---	---	96	79	80	109	---	---	---	32	---	---	---	---	---	---	---	28	31	46	0.75
	1½"	---	---	126	102	126	150	---	---	---	41	---	---	---	---	---	---	---	34	34	60	1.4
	2"	---	---	130	107	126	170	---	---	---	50	---	---	---	---	---	---	---	34	34	75	1.95
3"	---	---	191	163	185	310	110	---	68	100	---	---	---	---	---	---	---	---	62	120	13.4	
VGF...	DN40	13	3	126	102	126	200	---	---	---	41	19	150	110	88	45°	90°	4	36	36	---	6
	DN50	13	3	130	107	126	230	---	---	---	50	19	165	125	102	45°	90°	4	42	42	---	7.5
	DN65	16.5	3	191	163	185	290	108	148	95	92	19	185	145	120	45°	90°	4	---	---	---	15.3
	DN80	19	3	191	163	185	310	118	158	102	100	19	200	160	131	22.5°	45°	8	---	---	---	17.9
VGH...	DN80	15	3	---	---	160	310	102	---	105	159	19	200	160	131	22.5°	45°	8	95	95	---	16.3
	DN100	16	3	---	---	160	350	102	---	105	166	19	220	180	157	22.5°	45°	8	95	95	---	18.6
	DN125	17	3	---	---	160	400	102	---	121	174	19	250	210	187	22.5°	45°	8	95	95	---	23.4

1) Number of holes

For standards for flanges and threads, refer to «Type summary / Valves»

* Width across flats

VGH... / DN80...125

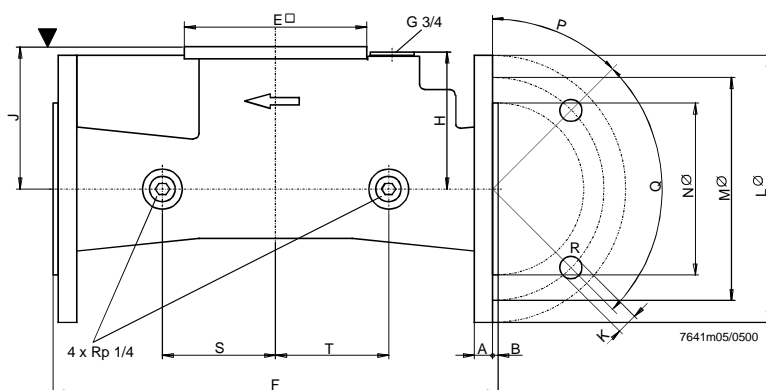

VGF... / DN 40...50

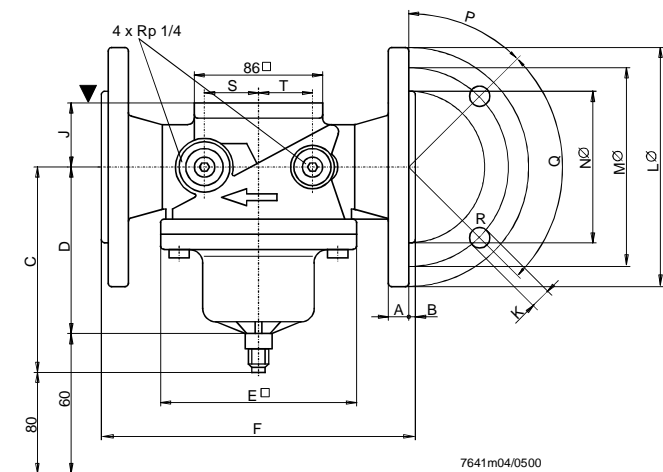

VGF... / DN 65...80

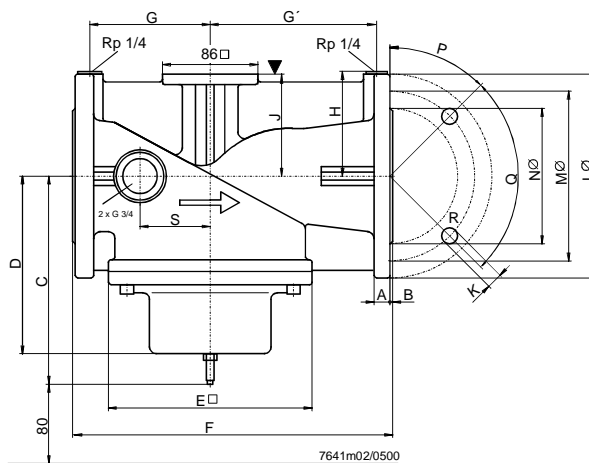

VGG3“

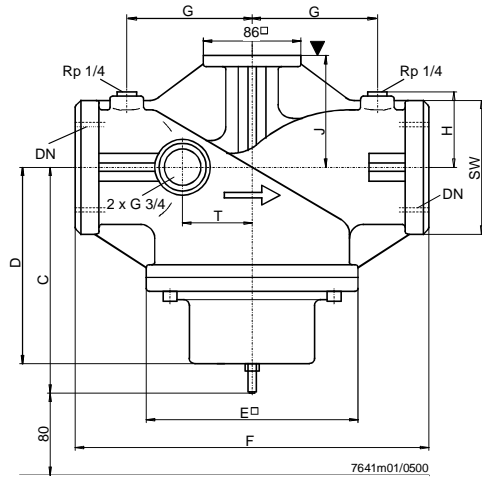

VGG 1/2”...2“

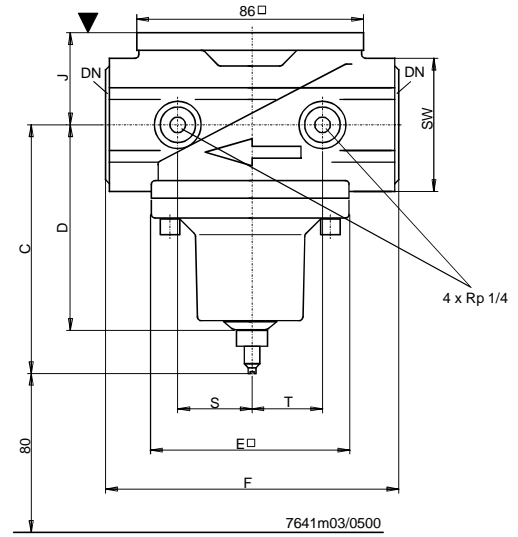

▼ Mounting surface for actuator SKP... or adapter flange AGA60 for SQX...